

D+CONNECT

REMOTE CONTROL FOR ELECTRONIC
RESIDENTIAL AND COMMERCIAL SYSTEMS



D.CONNECT SERVICE

REMOTE CONTROL FOR ELECTRONIC RESIDENTIAL AND COMMERCIAL SYSTEMS

The D.Connect service offers simple and intuitive remote control of your installation, without the need of a server or specialist personnel.

With D.Connect, you can remotely manage your installations as if you were right in front of them.

Thanks to the system operation charts, you will also be able to optimise operation. You will also receive prompt notifications of any system faults.

THE CONNECTIVITY SERVICE ALLOWS YOU TO:

EASILY MONITOR YOUR SYSTEMS

The installations with green status are OK, while the orange ones need attention, and the red ones are experiencing problems

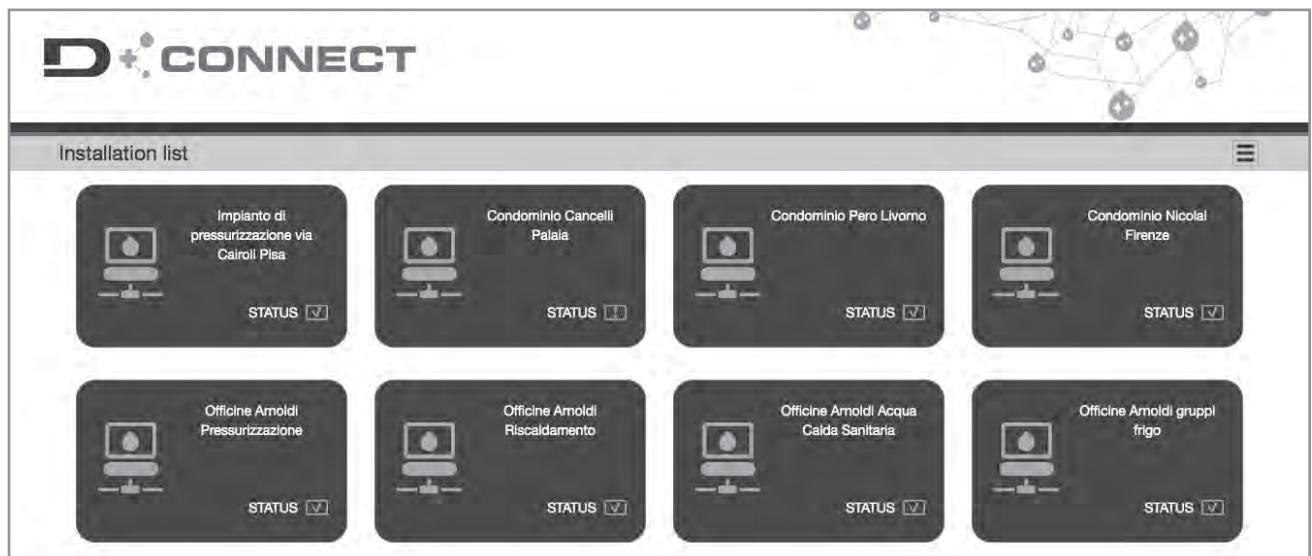

TAKE ANY NECESSARY ACTIONS AS IF YOU WERE RIGHT IN THE PUMP ROOM

Using the internet site or the APPs, you will be able to easily and quickly control your systems.

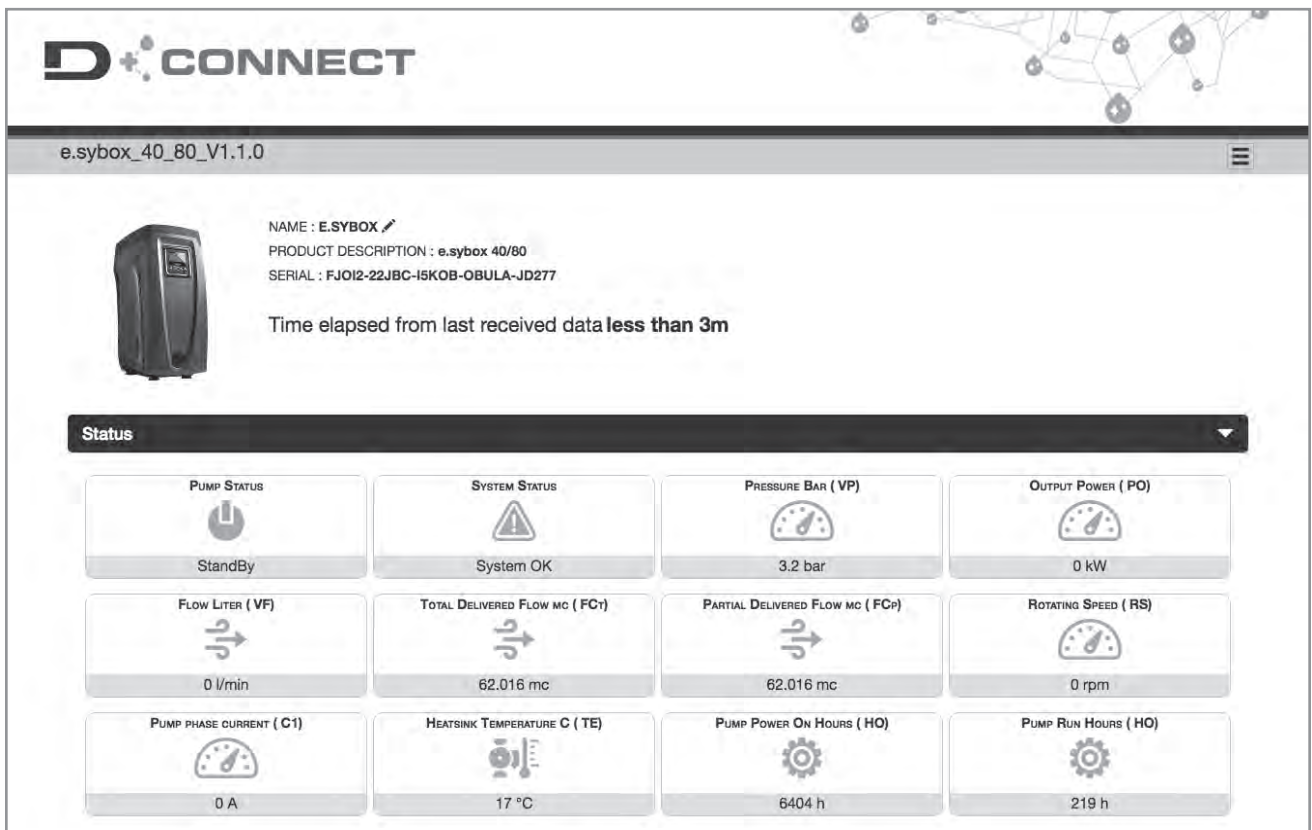

DCONNECT SERVICE

REMOTE CONTROL FOR ELECTRONIC RESIDENTIAL AND COMMERCIAL SYSTEMS

In order to use the DConnect service, registration and connected products are required.

Connect to the site: <https://dconnect.dabpumps.com> using Internet Browsers such as Microsoft Edge or Google Chrome.

The Android and iOS DCONNECT APPs can be downloaded from the relevant Stores:



REMOTE ALARMS

In case of alarm, the DConnect service will promptly send you a notification, so that you can check what is happening and organise a visit to the system before the issue becomes an emergency for your customer.

WHAT PRODUCTS CAN YOU MANAGE USING THE DCONNECT SERVICE?

MCE/P, MCE/C, ADAC, Active driver Plus, Ebox, Evoplus, Eskybox, Eskybox mini, Eskybox Diver, Dtron 3.

WHAT DO YOU NEED TO USE THE SERVICE?

1. DConnect Box / Dconnect Box 2
2. Cables for the connection of the DConnect Box / Dconnect Box 2 to the products to control
3. One or more compatible products
4. An internet connection in the system to control

For more information visit: www.internetofpumps.com

DCONNECT BOX

ELECTRONIC REMOTE CONTROL DEVICE



TECHNICAL DATA

DConnect Box power supply: 12V DC, Current: 1.5A

Power supply unit supplied: input 100-240VAC, with interchangeable plugs for the European, UK Australian and USA markets.

DConnect Box protection class: IP20

Connection to the Internet:

- Wi-Fi: Supports 802.11 b/g/n, WPA-PSK/WPA2-PSK encryption. Frequency 2.4 GHz

- Ethernet: Compliant with IEEE802.3 10Base-T and 100Base-TX standards

Assembly: DIN rail using the accessory supplied, or wall-mounted installation using the wall plugs supplied.

Maximum number of devices: The maximum number of pumps that can be controlled with DConnect Box is 8.

I/O external connections:

- 4 non opto-coupled inputs with voltage control
- 2 relay outputs

REQUIREMENTS:

DAB DConnect APP requirements:

Smartphone or Tablet:

- Android 7 or higher.
- iOS 11 or higher.
- Access to the Internet.

Network requirements:

- Permanent direct Internet connection (no login portals).
- 2.4Ghz Wi-Fi and/or LAN modem/router with active DHCP service.
- In case of Wi-Fi connection, good quality Wi-Fi signal at the DConnect Box installation area. In case of weak signal, we recommended the use of a Wi-Fi signal repeater.

PC requirements:

- Web Browser supporting Java script (e.g. Microsoft Edge or Firefox version 7.0 or higher, or Google Chrome).
- Access to the Internet.

APPLICATIONS:

DConnect Box is a compact electronic device that allows to easily connect to the DConnect service a wide range of DAB products, including already installed one. All it requires is a permanent network connection at the place of installation.

Using the DAB DConnect APP, available from Apple Store or Google Play, or connecting to the dconnect.dabpumps.com website, it is possible to go through the various connected installations, checking their individual setting parameters. All this, using an extremely clear and functional user interface that allows you to have a lot of information at your fingertips.

DConnect can be used in all the main fields of application: from pressurisation systems to circulation systems, from waste water recovery installations to swimming pool filtering systems.

It is a multi-channel service of high added value that can be used with any system, irrespective of its nature and size and in the same environment and with the same instruments.

Being modular, DConnect can manage up to 8 different electronic pumps in a highly simple and integrated manner.

DCONNECT BOX

ELECTRONIC REMOTE CONTROL DEVICE

COMPATIBLE PRODUCT CONNECTIONS:



DCONNECT BOX

ELECTRONIC REMOTE CONTROL DEVICE

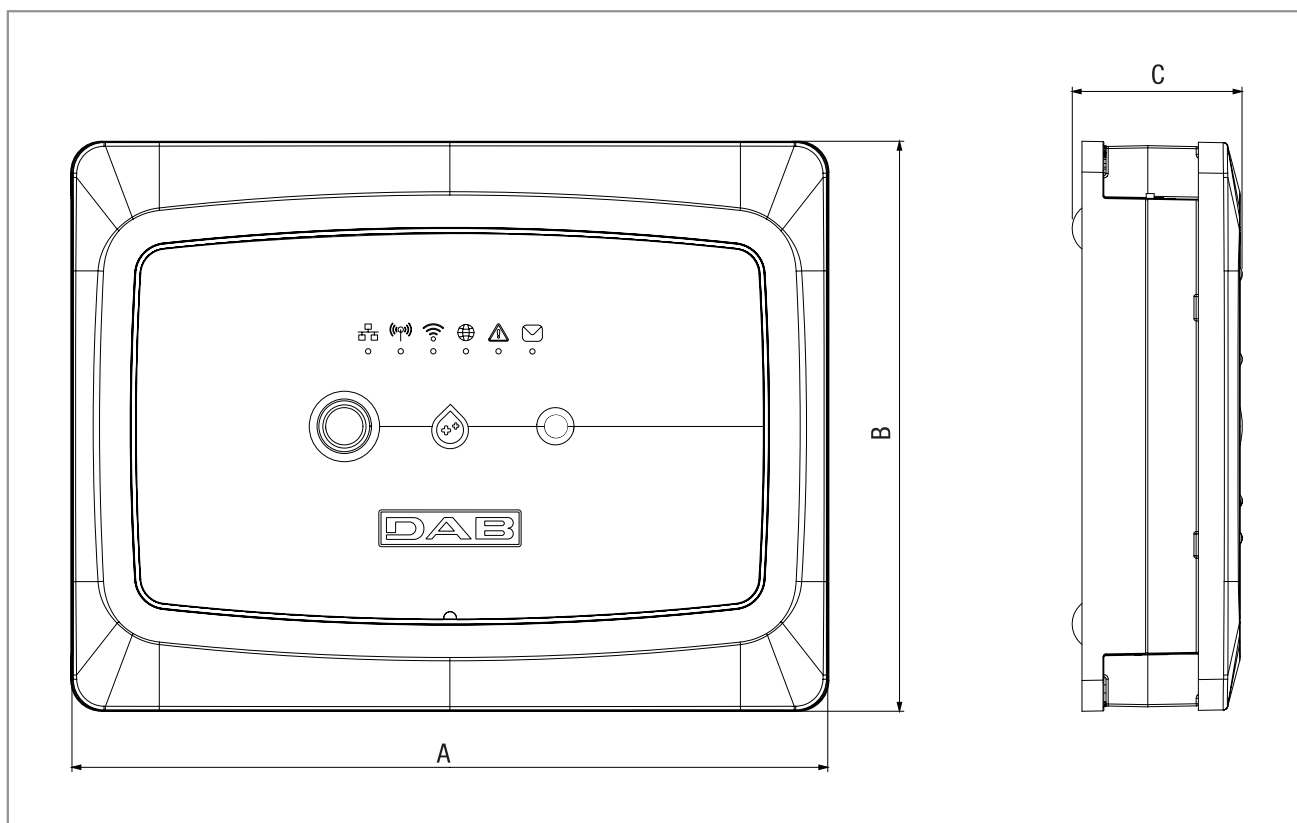

DIMENSIONS			PACKAGING DIMENSIONS			WEIGHT kg
A	B	C	L	B	H	
172	129.7	38.6	220	255	145	1.4



	LAN status LED
	Wireless status LED
	Wi-Fi status LED
	DAB Service Centre connection LED
	Generic Error LED
	Message LED
	DConnect drop LED

DCONNECT BOX

ELECTRONIC REMOTE CONTROL DEVICE

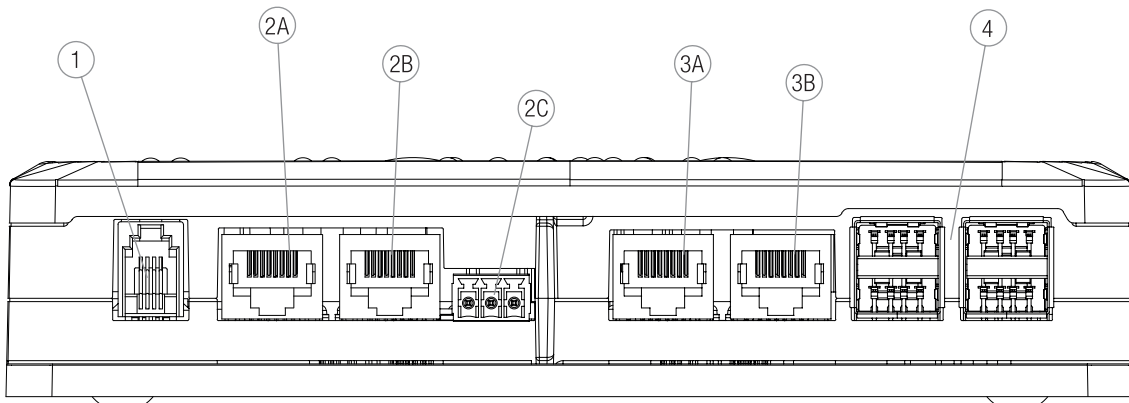

1	Serial Port
2A	ADAC/MCE CAN-BUS1 Port
2B	ADAC/MCE CAN-BUS1 Port
2C	ACTIVE DRIVER PLUS CAN-BUS1 Port
3A	ADAC/MCE CAN-BUS2 Port
3B	ADAC/MCE CAN-BUS2 Port
4	USB EBOX/Expansion Ports

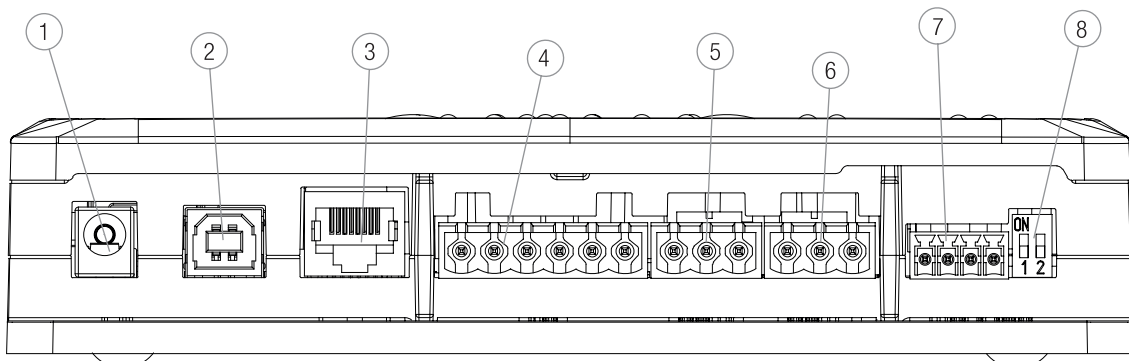

1	Power input / Power Jack
2	Host USB (Power input only)
3	Ethernet Port: LAN cable connection
4	I/O - 4 non opto-coupled inputs with voltage control
5	I/O - OUT1 output relay
6	I/O - OUT2 output relay
7	Modbus: Evoplus
8	Dip Switch: Modbus configuration

PACK CONTENT:

- DConnect Box.
- Wall-mounted power supply unit, plugin socket and ferrite core.
- Screws and plugs for wall-mounted installation.
- DIN rail installation bracket.
- Electric connectors for Modbus, Canbus, I/O, Relay connections.
- Instruction manual.

LICENSES: <http://dconnect.dabpumps.com/GPL>

DCONNECT BOX 2

ELECTRONIC REMOTE CONTROL DEVICE



TECHNICAL DATA

DConnect Box 2 power supply: 100/240 VAC 50/60Hz

Integrated power supply unit:

Schuko, UK, AUS, USA (nema5 e nema6), Sud Africa and Argentina

DConnect Box 2 protection class: IP20

Connection to the Internet:

- Wi-Fi: Supports 802.11 b/g/n, WPA-PSK/WPA2-PSK encryption. Frequency 2.4 GHz

Assembly: on the wall with fixing holes

Maximum number of devices: DConnect Box 2 can control up to a maximum of 4 pumps (depending on the type of pump)

I/O external connections:

- 1 non opto-coupled input with voltage control
- 1 relay output (24V 5A resistive load)

REQUIREMENTS:

DAB DConnect APP requirements:

Smartphone or Tablet:

- Android 7 or higher.
- IOs 11 or higher.
- WiFi enabled

Network requirements:

- Permanent direct Internet connection (no login portals)
- 2.4Ghz Wi-Fi modem/router with active DHCP service.
- Good quality Wi-Fi signal in the DConnect Box 2 installation area. In case of weak signal, we recommended the use of a Wi-Fi extender or additional Wi-Fi modem.

PC requirements:

- Web Browser supporting Java script (e.g. Microsoft Edge or Firefox version 7.0 or higher, or Google Chrome).
- Access to the Internet.

APPLICATIONS:

DConnect Box 2 is a compact electronic device for the control of domestic and residential pressurisation or irrigation panels or pumps. It has various connection ports and is based on innovative technologies, including powerline technology for communication with submersible pumps requiring only the one power cable, permitting the control of an extensive range of pumps. Remote controlled with the DConnect App (for Android or iOS) downloaded from a smartphone or tablet, or from the site dconnect.dabpumps.com. The DConnect service offers simple and intuitive remote control of your installation, without the need of a server or specialist personnel, in the same way as if you were physically in front of the pumps. You can also use the operation charts to optimise performance, and be immediately alerted to any system faults.

The DConnect App has a clear and functional user interface that allows you to access all the available data and browse the various installations connected and check the settings of each pump. It supports up to 4 different DAB products at the same time.

DCONNECT BOX 2

ELECTRONIC REMOTE CONTROL DEVICE

COMPATIBLE PRODUCT CONNECTIONS:



MODBUS



DCONNECT BOX 2

ELECTRONIC REMOTE CONTROL DEVICE

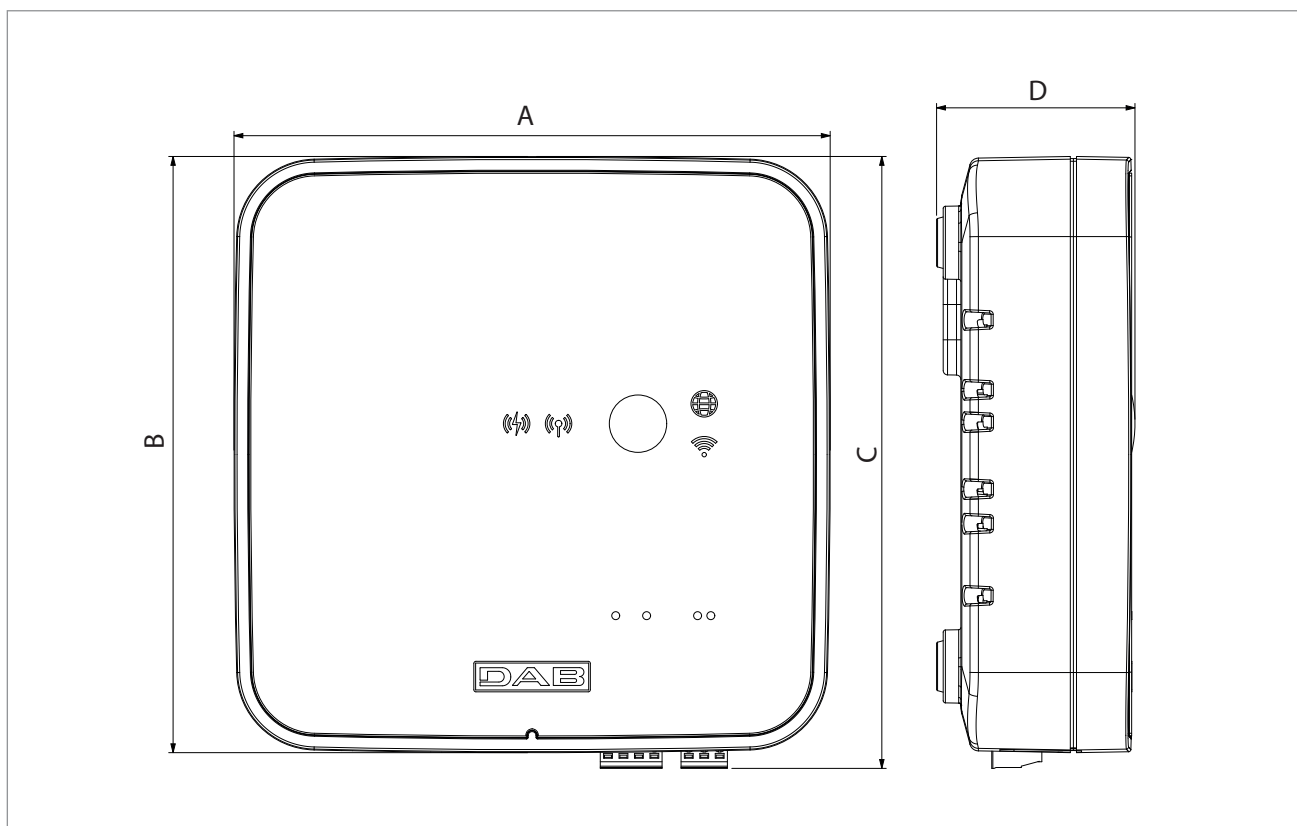

DIMENSIONS			PACKAGING DIMENSIONS			WEIGHT kg
A	B	C	L	B	H	
135	135	139.6	388	255	85	1.3



	PLC status LED
	Wireless status LED
	Wi-Fi status LED
	DAB DConnection Cloud connection LED

DCONNECT BOX 2

ELECTRONIC REMOTE CONTROL DEVICE

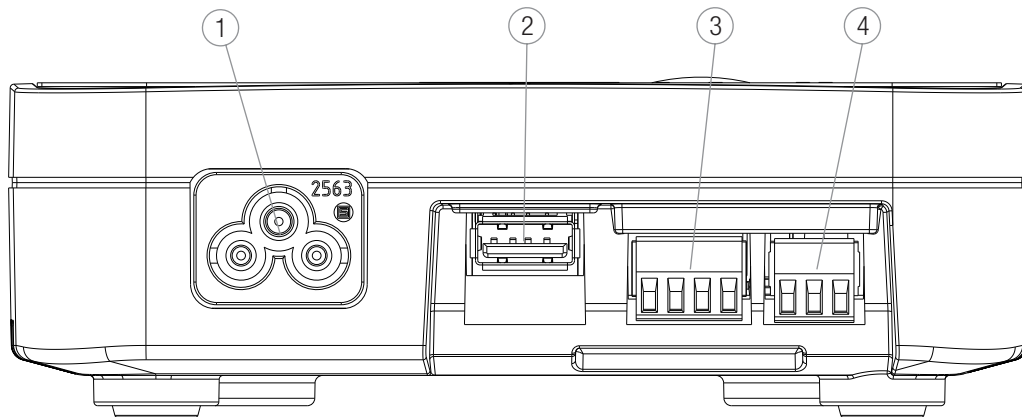

1	1x100-240 V ~ power plug
2	USB port for EBOX and accessories
3	Input/Output port
4	MODBUS RS485 port

PACK CONTENT:

- DConnect Box 2.
- Power cable.
- Electric connectors for Modbus, I/O connections.
- Quick Guide.

LICENSES: <http://dconnect.dabpumps.com/GPL>

DNA[®]

PUMPS SELECTOR



On-line product selection

 **DAB PUMPS LTD.**
6 Gilbert Court
Newcomen Way
Severalls Business Park
Colchester
Essex
CO4 9WN - UK
salesuk@dwtgroup.com
Tel. +44 0333 777 5010

 **DAB PUMPS IBERICA S.L.**
Calle Verano 18-20-22
28850 - Torrejón de Ardoz - Madrid
Spain
Info.spain@dwtgroup.com
Tel. +34 91 6569545
Fax: +34 91 6569676

 **DAB PUMPS SOUTH AFRICA (PTY) LTD**
Twenty One industrial Estate,
16 Purlin Street, Unit B, Warehouse 4
Olifantsfontein -1666 - South Africa
info.sa@dwtgroup.com
Tel. +27 12 361 3997

 **DAB PUMPS BV**
'tHofveld 6 C1
1702 Groot Bijgaarden - Belgium
info.belgium@dwtgroup.com
Tel. +32 2 4668353

 **DAB PUMPS HUNGARY KFT.**
H-8800
Nagykanizsa, Buda Ernő u.5
Hungary
Tel. +36 93501700

 **DAB PUMPS (QINGDAO) CO. LTD.**
No.40 Kaituo Road, Qingdao Economic & Technological
Development Zone
Qingdao City, Shandong Province - China
PC: 266500
sales.cn@dwtgroup.com
Tel. +86 400 186 8280
Fax +86 53286812210

 **DAB PUMPS B.V.**
Albert Einsteinweg, 4
5151 DL Drunen - Nederland
info.netherlands@dwtgroup.com
Tel. +31 416 387280
Fax +31 416 387299

 **DAB PUMPS POLAND Sp. z o.o.**
Ul. Janka Muzykanta 60
02-188 Warszawa - Poland
polska@dabpumps.com.pl

 **DAB PUMPS DE MÉXICO, S.A. DE C.V.**
Av Amsterdam 101 Local 4
Col. Hipódromo Condesa,
Del. Cuauhtémoc CP 06170
Ciudad de México
Tel. +52 55 6719 0493

 **DAB PUMPEN DEUTSCHLAND GmbH**
Tackweg 11
D - 47918 Tönisvorst - Germany
info.germany@dwtgroup.com
Tel. +49 2151 82136-0
Fax +49 2151 82136-36

 **OOO DAB PUMPS**
Novgorodskaya str. 1, block G
office 308, 127247, Moscow - Russia
info.russia@dwtgroup.com
Tel. +7 495 122 0035
Fax +7 495 122 0036

 **DAB PUMPS OCEANIA PTY LTD**
426 South Gippsland Hwy,
Dandenong South VIC 3175 - Australia
info.oceania@dwtgroup.com
Tel. +61 1300 378 677

 **DAB PUMPS INC.**
3226 Benchmark Drive
Ladson, SC 29456 - USA
info.usa@dwtgroup.com
Tel. 1- 843-797-5002
Fax 1-843-797-3366